

PS3X Switching Power Supplies

Output 15W, 25W, 50W, 75W and 100W.
Compliant with international standards.

- Universal AC input voltage.
- Five output types (15W, 25W, 50W, 75W, 100W) and three output voltage types (5V, 12V, 24V).
- EMC, EN55032 Class B compliant.
- Available with mounting brackets for direct or DIN rail mounting.



• BAUART
• GEPROBT
• TYPE
• APPROVED



• See website for details on approvals and standards.

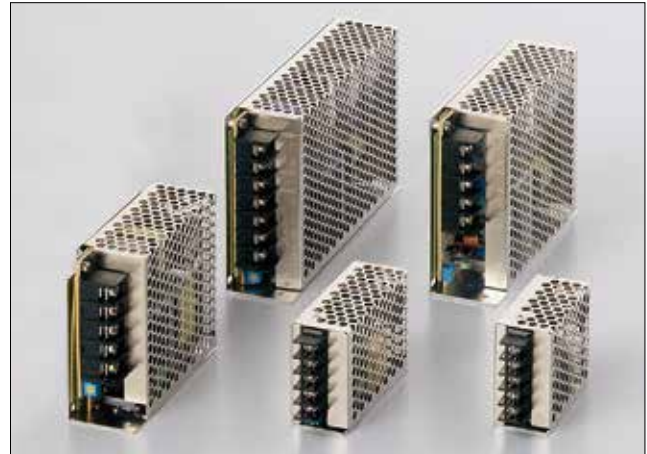

PS3X

Package Quantity: 1

Output Capacity	Horizontal Terminal	Vertical Terminal	Input Voltage	Output Voltage	Output Current
	Part No.	Part No.			
15W	PS3X-B05AFC	—	100 to 240V AC	5V	3.0A
	PS3X-B12AFC	—		12V	1.3A
	PS3X-B24AFC	—		24V	0.63A
25W	PS3X-C05AFC	—		5V	5.0A
	PS3X-C12AFC	—		12V	2.1A
	PS3X-C24AFC	—		24V	1.1A
50W	PS3X-D12AFC	PS3X-D12AFG		12V	4.2A
	PS3X-D24AFC	PS3X-D24AFG		24V	2.2A
75W	PS3X-Q05AFC	PS3X-Q05AFG		5V	12.0A
	PS3X-Q12AFC	PS3X-Q12AFG		12V	6.0A
	PS3X-Q24AFC	PS3X-Q24AFG		24V	3.2A
100W	PS3X-E05AFC	PS3X-E05AFG		5V	16.0A
	PS3X-E12AFC	PS3X-E12AFG		12V	8.5A
	PS3X-E24AFC	PS3X-E24AFG		24V	4.5A

L-shaped Mounting Bracket (optional)

Applicable Power Supply	Part No.
PS3X-B	PS9Z-3N3A
PS3X-C	PS9Z-3N3B
PS3X-D	PS9Z-3E3B
PS3X-Q	PS9Z-3N3E
PS3X-E	

- See page 6 for dimensions.
- Package quantity: 1

DIN-rail Mounting Bracket (optional)

Applicable Power Supply	Part No.
PS3X-B	PS9Z-3N4B
PS3X-C	
PS3X-D	PS9Z-3E4C
PS3X-Q	PS9Z-3E4D
PS3X-E	

- Package quantity: 1

Din Rail

Length	Part No.	Ordering No.	Material	Weight	Package Quantity
1000 mm	BAA1000	BAA1000PN10	Aluminum	200g	10
	BAP1000	BAP1000PN10	Steel	320g	

End Clip

Part No.	Ordering No.	Package Quantity
BNL5	BNL5PN10	10
BNL6	BNL6PN10	

Part No. Development

PS3X - B 05 AF C

Output Capacity Code

B: 15W
C: 25W
D: 50W
Q: 75W
E: 100W

Output Voltage Code

05: 5V DC (15W, 25W, 75W, 100W)
12: 12V DC
24: 24V DC

Cover and Terminal Style Code

C: w/Standard cover,
Horizontal terminal block
G: w/Standard cover,
Vertical terminal block

Input Voltage Code

AF: 100 to 240V AC

Specifications

Description		Power Supplies	PS3X-B05/B12/B24 (15W)	PS3X-C05/C12/C24 (25W)	PS3X-D12/D24 (50W)	PS3X-Q05/Q12/Q24 (75W)	PS3X-E05/E12/E24 (100W)		
Input	Rated Input Voltage	100 to 240V AC							
	Voltage Range (Note 1)	85 to 264V AC/ 120 to 375V DC		88 to 264V AC / 125 to 375V DC					
	Frequency	47 to 63 Hz							
	Input Current	0.5A max.		0.65A max.	1.3A max.	1.8A max.	2.5A max.		
	Inrush Current (Ta = 25°C, cold start)	at 115V AC	40A max.		30A max.	30A max.	30A max.	35A max.	
		at 230V AC	60A max.		50A max.	50A max.	50A max.	70A max.	
	Leakage Current	0.5mA max.		1.5mA max.	1.5mA max.	1.5mA max.	1.5mA max.		
Efficiency (Typ.) (230V AC at input/ rated output)	5V	77%	77%	—	77%	77%			
	12V	81%	81%	81%	82%	81%			
	24V	82%	84%	84%	84%	84%			
Output	Rated Voltage/Current	5V, 3A		5V, 5A	—	5V, 12A	5V, 16A		
		12V, 1.3A		12V, 2.1A	12V, 4.2A	12V, 6A	12V, 8.5A		
		24V, 0.63A		24V, 1.1A	24V, 2.2A	24V, 3.2A	24V, 4.5A		
	Adjustable Voltage Range	±10%							
	Output Holding Time (at rated output)	13 ms typ. (100V AC) 60 ms min. (230V AC)		10 ms typ. (100V AC) 60 ms min. (230V AC)	23 ms typ. (100V AC) 60 ms min. (230V AC)	14 ms typ. (100V AC) 60 ms min. (230V AC)	17 ms typ. (100V AC) 80 ms min. (230V AC)		
	Start Time	1000 ms max. (230V AC input, rated output)							
	Rise Time	50 ms max. (230V AC input, rated output)		30 ms max. (230V AC input, rated output)	30 ms max. (230V AC input, rated output)	30 ms max. (230V AC input, rated output)	30 ms max. (230V AC input, rated output)		
		50 ms max. (230V AC input, rated output)		30 ms max. (230V AC input, rated output)	30 ms max. (230V AC input, rated output)	30 ms max. (230V AC input, rated output)	30 ms max. (230V AC input, rated output)		
	Regulation (including noise)	Input Fluctuation	0.5% max.						
		Load Fluctuation	5V: ±2% max. 12V, 24V: ±1% max.						
		Temperature Fluctuation	0.04% / °C max. (-20 to +50°C)			0.04% / °C max. (-10 to +45°C)			
		Ripple	-20 to -10°C	5V: 200 mV max. 12V/24V: 200 mV max.		5V: 140 mV max. 12V: 240 mV max. 24V: 300 mV max.	—	—	—
			-10 to 0°C	5V: 160 mV max. 12V/24V: 200 mV max.		5V: 140 mV max. 12V: 240 mV max. 24V: 300 mV max.	12V: 240 mV max. 24V: 300 mV max.	5V: 140 mV max. 12V: 240 mV max. 24V: 300 mV max.	5V: 160 mV max. 12V: 240 mV max. 24V: 300 mV max.
	PS3X-B, C: 0 to +50°C PS3X-D, Q, E: 0 to +45°C		5V: 100 mV max. 12V/24V: 150 mV max.		5V: 70 mV max. 12V: 120 mV max. 24V: 150 mV max.	12V: 120 mV max. 24V: 150 mV max.	5V: 70 mV max. 12V: 120 mV max. 24V: 150 mV max.	5V: 100 mV max. 12V: 120 mV max. 24V: 150 mV max.	
Supplementary Functions	Overcurrent Protection	105% min. (auto reset) (Note 2)							
	Overvoltage Protection	Voltage limitation at 115% min.			Intermittent operation or output off at 115% min. (Note 3)				
	Operation Indicator	LED (green)							
Dielectric Strength	Between input and output terminals	3000V AC, 1 minute (at 25°C, 70% RH)							
	Between input and ground terminals	2000V AC, 1 minute (at 25°C, 70% RH)							
	Between output and ground terminals	500V AC, 1 minute (at 25°C, 70% RH)							
Insulation Resistance	100MΩ min. 500V DC megger (at 25°C, 70% RH) (between input and output terminals, between input and ground terminals)								
Operating Temperature	-20 to +70°C (no freezing, see output derating)			-10 to +70°C (no freezing, see output derating)					
Operating Humidity	20 to 85% RH (no condensation)								
Storage Temperature	-40 to +85°C (no freezing)								
Storage Humidity	10 to 95% RH (no condensation)								
Vibration Resistance	10 to 55 Hz, 2G constant, 2 hours each in 3 axes								
Shock Resistance	200m/s ² , 1 shock each in 6 axes								
EMC	EMI	EN55032 Class B							
	EMS	EN55024							
Safety Standards	IEC/EN60950-1, UL60950-1, CSA C22.2 No. 60950-1								
Dimensions (H × W × D) (mm)	50.8H × 28W × 62D		50.8H × 28.5W × 79D	82H × 35W × 99D	95H × 38W × 129D	95H × 38W × 159D			
Weight (approx.)	130g		180g	340g	500g	540g			
Terminal Screw	M3			M3.5					

Note 1: DC input voltage is not subjected to safety standards. The input voltage range approved by safety standards is 100 to 240V AC.

When using on DC input, connect a fuse to the input terminal for DC input protection.

Note 2: Overload for 30 seconds or longer may damage the internal elements.

Note 3: One minute after the output has been turned off, turn on the AC input again.

Characteristics

Operating Temperature vs. Output Current (Derating Curves)

Conditions: Natural air cooling (operating temperature is the temperature around the power supply)

PS3X-B/C

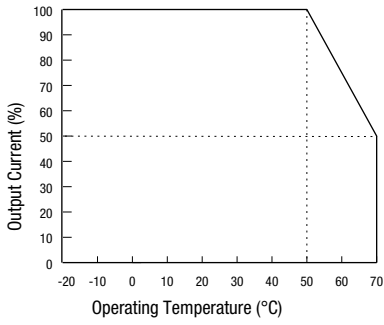

PS3X-D/Q/E

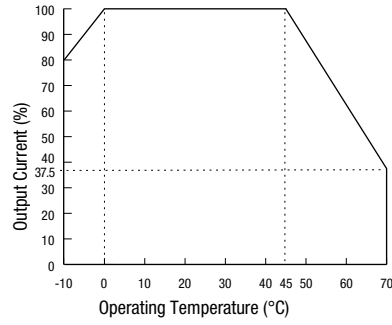

Overcurrent Protection Characteristics

PS3X

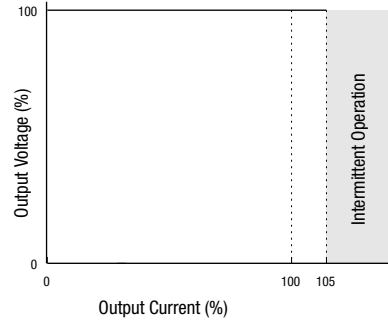

Output Current vs. Input Voltage (TA = 25°C)

PS3X-B/C

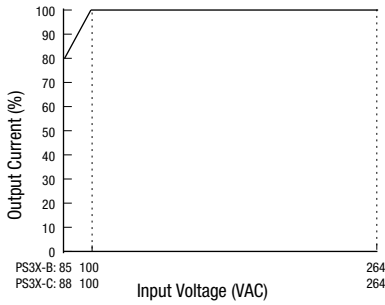

PS3X-D/Q/E

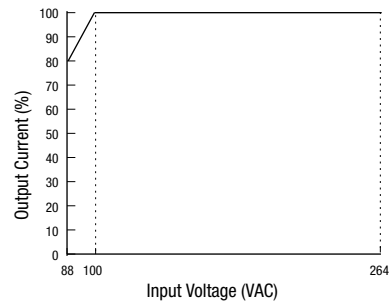

Operating Temperature by Safety Standards

Power Supplies	UL/EN60950-1
	Mounting A, B
PS3X-B05, -B12, -B24 PS3X-C05, -C12, -C24	50°C
PS3X-D12, -D24 PS3X-Q05, -Q12, -Q24 PS3X-E05, -E12, -E24	45°C

Note: Observe the derating curves when operating PS3X power supplies.

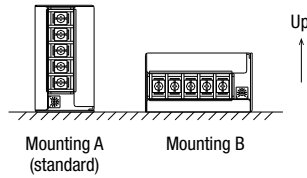

Dimensions

All dimensions in mm.
General tolerance: ± 1 mm

PS3X-B

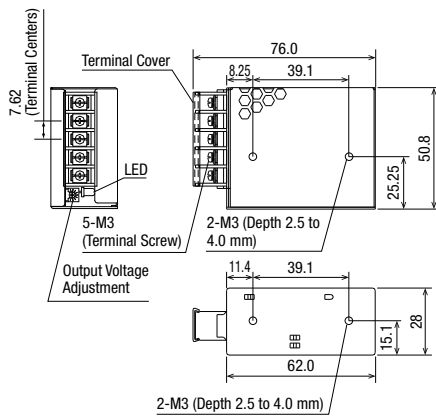

PS3X-C

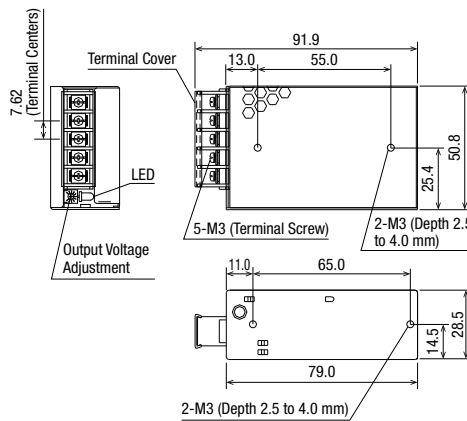

PS3X-D□AFG

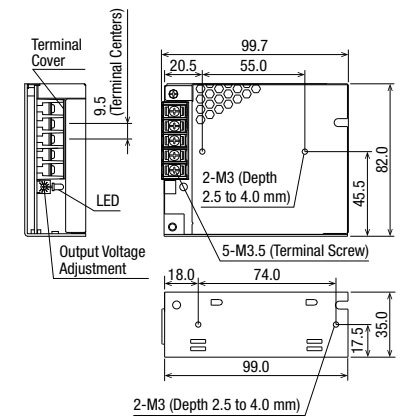

PS3X-D□AFC

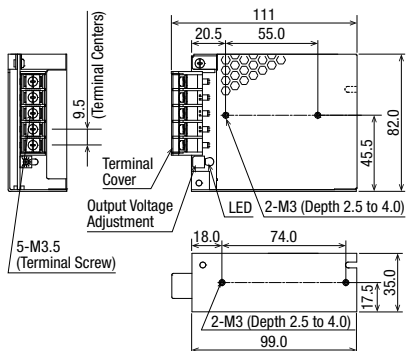

PS3X-Q□AFG

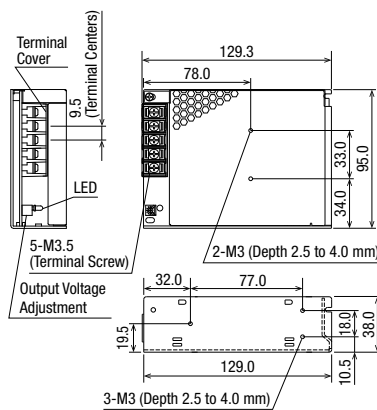

PS3X-Q□AFC

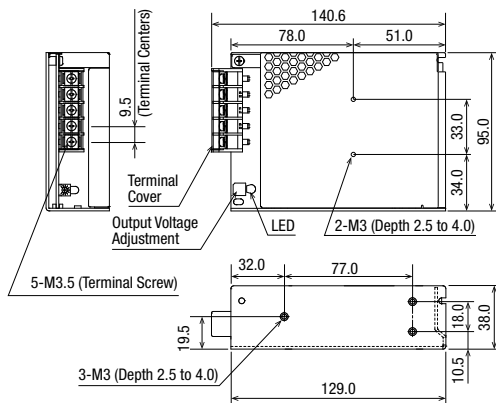

PS3X-E□AFC

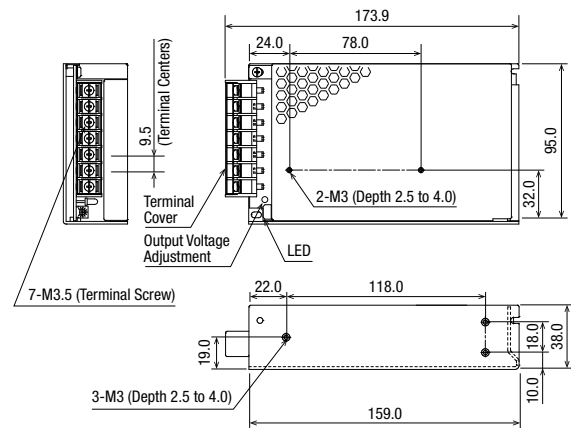

PS3X-E□AFG

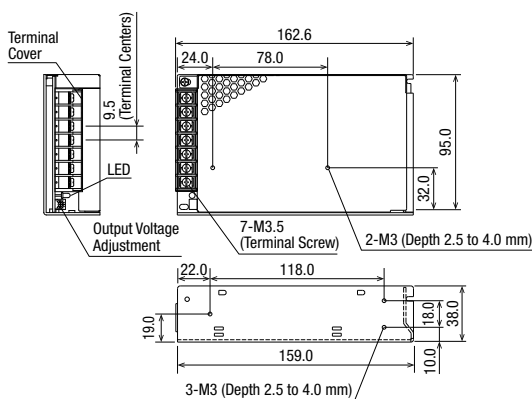

Precaution on mounting screws
Use M3 screw as mounting screws. Choose screws that protrudes for 2.5 to 4mm from the surface of the switching power supply.

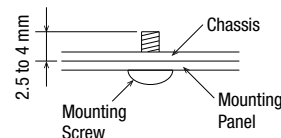

Parts Description

Pay attention to wiring, as terminal arrangement is different from that of other IDEC power supplies.

PS3X-B/C

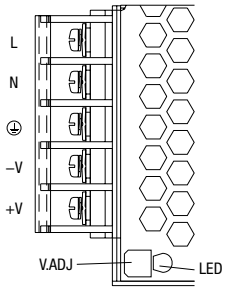

PS3L-A/B (reference)

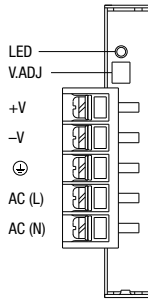

PS3N-A/B/C (reference)

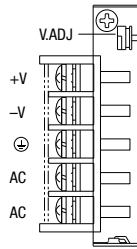

PS3X-D/Q□AFG

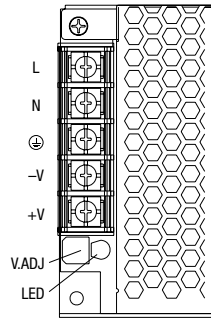

PS3L-C/D (reference)

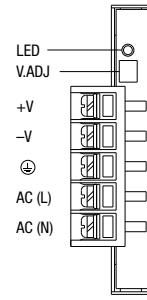

PS3N-D (reference)

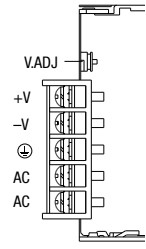

PS3X-D/Q□AFC

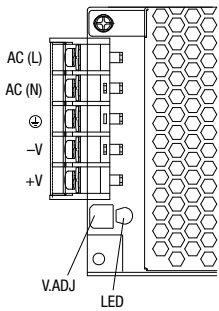

PS3L-C/D (reference)

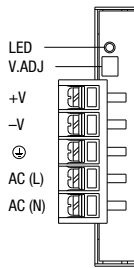

PS3N-D (reference)

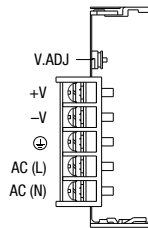

PS3X-E□AFG

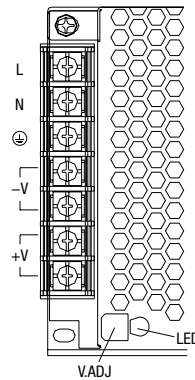

PS3L-E (reference)

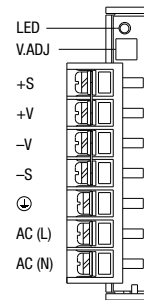

PS3N-E (reference)

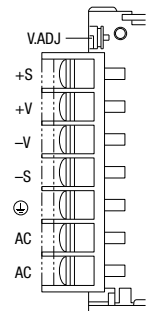

PS3X-E□AFC

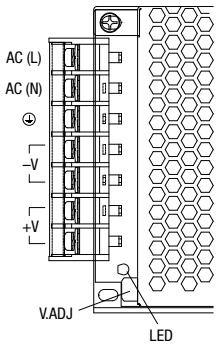

PS3L-E (reference)

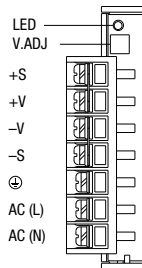

PS3N-E (reference)

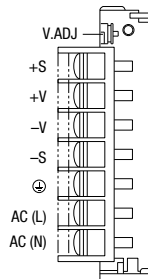

Marking	Name	Description
L, N	AC Input Terminal	Accepts a wide range of voltage and frequency. Polarity is irrelevant at DC input.
⊕	Ground Terminal	Be sure to connect this terminal to a proper ground.
+V, -V	DC Output Terminals	+V: Positive output terminal -V: Negative output terminal
+S, -S (Note)	Remote Sensing Terminal	Compensates for voltage drops along the output line. Remove the jumpers when using remote sensing.
V.ADJ	Output Voltage Adjustment	Allows adjustment within ±10%. Turning clockwise increases the output voltage.
LED	Operation Indicator	Lights on when the output voltage is on.

Note: PS3X does not have +S or -S terminals.

L-shaped Mounting Bracket

All dimensions in mm.

PS9Z-3N3A (for 15W)

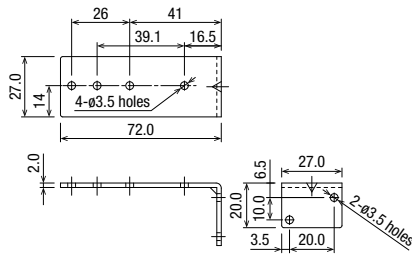

PS9Z-3N3B (for 25W)

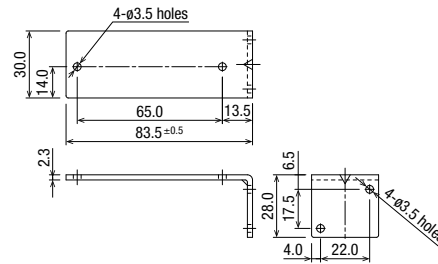

PS9Z-3E3B (for 50W)

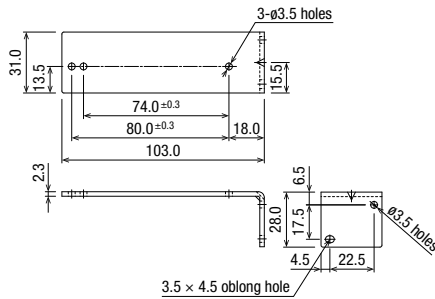

PS9Z-3N3E (for 75W/100W)

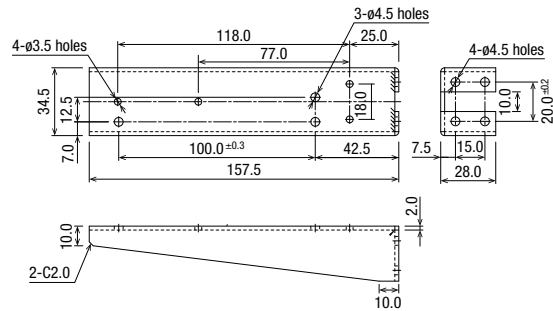

DIN-rail Mounting Bracket

All dimensions in mm.

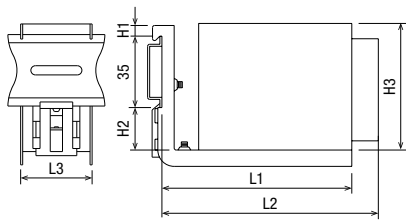

Part No.	Applicable Power Supply	L1	L2	L3	H1	H2	H3
PS9Z-3N4B	PS3X-B	93	104.4	35	5.2	20.5	50.8
	PS3X-C	93	111.9	35	5.2	20.5	50.8
PS9Z-3E4C	PS3X-D	134	113.7	35	5.2	20.5	82
PS9Z-3E4D	PS3X-Q	186	139.3	39.5	5.2	19.4	95
	PS3X-E	186	173.6	39.5	5.2	19.4	95

Note: L2 is larger than L1.

! Safety Precautions

- Do not use switching power supplies with equipment whose malfunction or inadvertent operation may damage the human body or life directly, such as medical, aerospace, railway, nuclear, etc.). PS3X switching power supplies are designed for the use in general electric equipment such as office, communication, measuring, and industrial electric devices.
- Do not disassemble, repair, or modify the power supplies, otherwise electric shock, fire, or malfunction will result.
- Do not install the switching power supply in places where it touches the human body while input voltage is applied. Do not touch the switching power supply while input voltage is applied and right after the power turned off, because high temperature and high voltage will cause burns and electric shocks. Standard switching power supply is for embedded use.
- Do not short the output terminals or output lead wires, otherwise fire or damage will result.
- Provide the final product with protection against malfunction or damage that may be caused by malfunction of the switching power supply. Damaged switching power supply may cause overvoltage on the output terminals, or may cause voltage drop.
- Turn off power before wiring. Also, make sure to wire correctly. Improper wiring may cause electric fire or damage.
- Do not use switching power supplies to charge rechargeable batteries.
- Make sure that the input voltage does not exceed the rating. Note polarity of input and output terminals and wire correctly. Incorrect wiring may cause blown fuse of AC line, smoke, or fire.
- Do not touch inside the switching power supply, and make sure that no foreign object enters inside the switching power supply, otherwise accidents or failure will occur.
- Observe the temperature derating curves. Operating temperature indicates the temperature around the lower part of the switching power supply. Failure to observe the derating curves will result in the internal temperature rise and failure of the switching power supply.
- The fuse inside the switching power supply is for AC input. When using with DC input, install an external fuse.
- Do not turn the V. ADJ control over the setting range, otherwise performance deterioration or failure will occur.
- When failure or error occurs, shut down the input to the switching power supply, and contact IDEC.
- Do not use or store the switching power supply in a place subject to extreme vibration or shocks, otherwise failure will result.
- Do not use the switching power supply where it is subject to or near:
 - * Direct sunlight, heater, or high temperatures.
 - * Metal powder, oil, chemicals, or hydrogen sulfide
 - * Highly humid areas, such as basement or conservatory
 - * Inside freezers or refrigerators, near cooler exhaust, or other cold places

Instructions

Notes for installation

- When mounting the PS3X switching power supply, see the figure on the right.

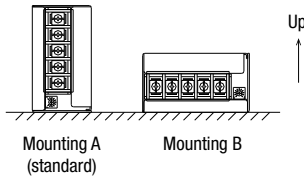

- See page 6 for mounting hole layout.
- Use M3 screw as mounting screws. Choose screws that protrudes for the length of L (see the table below) from the surface of the switching power supply.

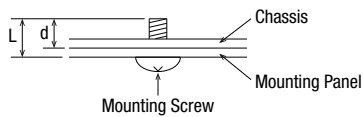

Part No.	d (mm)	L (mm)
PS3X-B□, -D□	2.5 to 3.8	Mounting panel thickness + d
PS3X-C□	1.7 to 3.0	
PS3X-Q□, -E□	3.7 to 5.0	

- Do not close the openings of the switching power supply. Ensure proper heat dissipation by convection.
- Maintain a minimum of 20 mm clearance around the switching power supply.
- When derating of the output does not work, provide forced air-cooling.
- Make sure to wire the ground terminal correctly.
- For wiring, use wires with heat resistance of 60°C or higher. Use copper wire.
- Recommended tightening torque of terminal screws: 0.8 N·m

Adjustment of Output Voltage

The output voltage can be adjusted within $\pm 10\%$ of the rated output voltage by using the V.ADJ control. Turning the V.ADJ clockwise increases the output voltage. Turning counterclockwise decreases the output voltage. Note that overvoltage protection may work when increasing the output voltage.

Overcurrent Protection

The output voltage drops automatically when an overcurrent flows, resulting in intermittent operation. Normal voltage is automatically restored when the load returns to normal conditions. However, overcurrent for a prolonged period of time or short-circuit causes the internal elements to deteriorate or break down.

Overvoltage Protection

(PS3X-B/C)

Voltage limit and auto-recovery method. The switching power supplies operate normally when voltage returns to normal.

(PS3X-D/Q/E)

The output is turned off or intermittent operation when an overvoltage is applied. When the output voltage has dropped due to an overvoltage, turn the input off, and after one minute, turn the input on again.

Series Operation

When connecting two switching power supplies in series, insert a Schottky diode to each output.

Parallel Operation

Parallel operation is not possible.

Insulation/Dielectric Test

When performing an insulation/dielectric test, short the input (between AC) and output (between + and -). Do not apply or interrupt the voltage suddenly, otherwise surge voltage may be generated and the power supply may be damaged.

Warranty

Scope

IDEC agrees to repair or replacement of the PS3X switching power supply if the product has been operated under the following conditions. The maximum value of output capacity shall be within the range of Operating Temperature vs. Output Current shown on page 5.

- Average operating temperature (ambient temperature of switching power supply) is 40°C at maximum.
- Average load factor is 80% at maximum.
- Rated input voltage
- Standard mounting style

IDEC CORPORATION

 www.idec.com

Head Office

6-64, Nishi-Miyahara-2-Chome, Yodogawa-ku, Osaka 532-0004, Japan

USA	IDEC Corporation	Tel: +1-408-747-0550	opencontact@idec.com	Hong Kong	IDEC Izumi (H.K.) Co., Ltd.	Tel: +852-2803-8989	info@hk.idec.com
Germany	APEM GmbH	Tel: +49-40-25 30 54 - 0	service@eu.idec.com	China/Shanghai	IDEC (Shanghai) Corporation	Tel: +86-21-6135-1515	idec@cn.idec.com
Singapore	IDEC Izumi Asia Pte. Ltd.	Tel: +65-6746-1155	info@sg.idec.com	China/Shenzhen	IDEC (Shenzhen) Corporation	Tel: +86-755-8356-2977	idec@cn.idec.com
Thailand	IDEC Asia (Thailand) Co., Ltd.	Tel: +66-2-392-9765	sales@th.idec.com	China/Beijing	IDEC (Beijing) Corporation	Tel: +86-10-6581-6131	idec@cn.idec.com
Australia	IDEC Australia Pty. Ltd.	Tel: +61-3-8523-5900	sales@au.idec.com	Japan	IDEC Corporation	Tel: +81-6-6398-2527	marketing@idec.co.jp
Taiwan	IDEC Taiwan Corporation	Tel: +886-2-2577-6938	service@tw.idec.com				

Specifications and other descriptions in this brochure are subject to change without notice.
Information in this brochure is current as of July, 2020.
2020 IDEC Corporation, All Rights Reserved.

EP1600-3

